

Speedmaster XL 106

HEIDELBERG

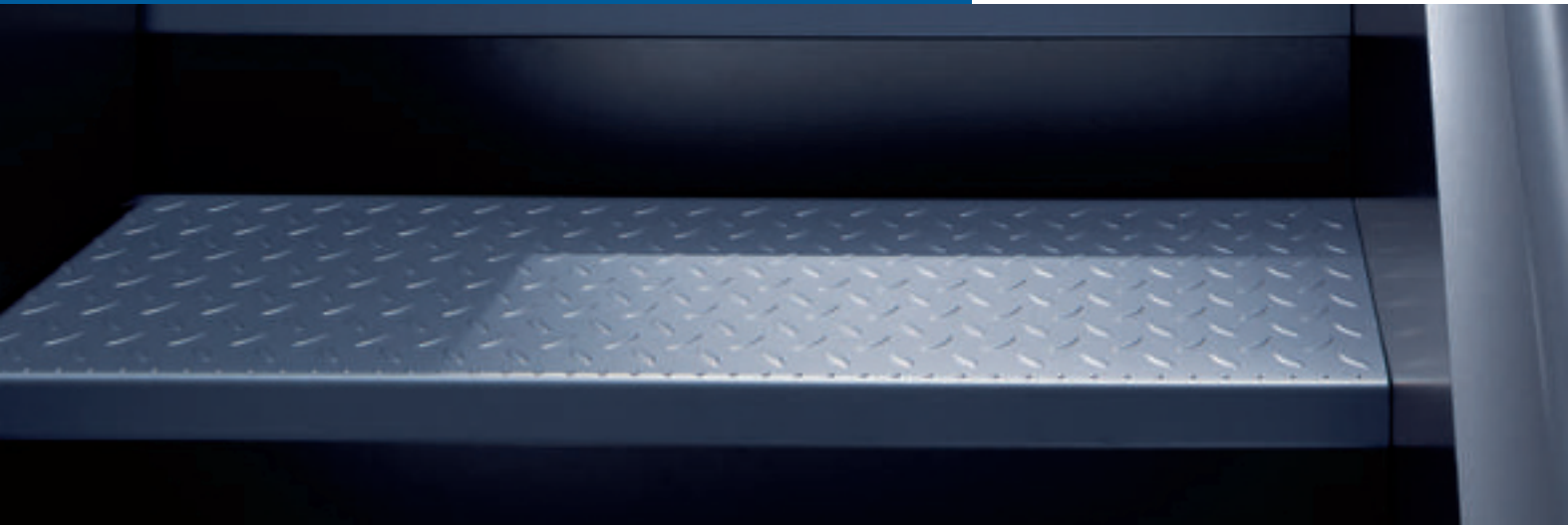



Welcome to the Peak Performance Class. Speedmaster XL 106 – the New Benchmark for Outstanding Performance.

4	Speedmaster XL 106
6	Feeder
8	Printing and Coating Unit
10	Inking and Dampening System
12	Sheet Travel and Perfecting Device
14	Delivery
16	Press Control System
17	Peripherals
18	Heidelberg Services
19	Inside View
21	Heidelberg Solutions

Peak Performance Class – Technology and Productivity that Know no Compromise.



Speedmaster XL 106 – a new dimension in print technology.

Outstanding performance day after day.

With the introduction of the Speedmaster® XL 105 at drupa 2004, a new performance class was launched for industrialized commercial, label, and packaging printing. Since then, it has served as the benchmark for production speed, print stability, and output. With over 1,200 installations on the market, it is the only machine in this performance class. The new Speedmaster XL 106 breaks all records in terms of productivity.

The very best. The Speedmaster XL 106 is a logical development of the successful Speedmaster XL 105. The perfect interplay between preset functions, ink presettings, a machine that is designed through-out for maximum performance, and straightforward operation ensures that the Speedmaster XL 106 is the Peak Performance machine in the 70 × 100 centimeters (27.56 × 39.37 inches) format.

The press delivers 18,000 sheets per hour in both straight and perfecting printing. The Speedmaster XL 106 with perfecting device sets new standards in pioneering technology – a fact underlined by a 20 percent increase in productivity.

The technology generation of the future. When you're aiming for success, you need reliable and powerful equipment. The Hycolor® inking and dampening system combines with the Color Package to deliver the best possible color stability throughout the run in record time – at any speed. In addition to being designed for high material throughput, the Speedmaster XL 106 also breaks new ground in the production of short runs. Depending on the particular job structure, it can produce between 60 and 80 million sheets a year with ease and change between 90,000 and 100,000 printing plates a year on an eight-color press. Thanks to its outstanding performance, this press raises the bar to an all-new high.

Configured for success. The Speedmaster XL 106 offers the broadest range of configurations – from two to 17 units – and can process materials ranging from in-mold foils to kraft board, with or without a perfecting device. It can be customized to your very specific requirements, for example in an L-P-L and Duo configuration, or as a rotary die cutter for products such as in-mold labels. It is even possible to integrate inkjet units for marking individual multiple-ups as waste or for imprinting alphanumeric codes. The flexibility of the Speedmaster XL 106 ensures you are streets ahead of your competitors.

Peak Performance in ecological printing. As a pioneer of ecological printing, Heidelberg® develops solutions to eliminate or reduce carbon dioxide (CO₂) and process emissions and cut waste. Consequently, the technology of the Speedmaster XL 106 sets standards in more than just productivity. Its high energy and resource efficiency make it the most environmentally friendly press in its class. This is documented by the “Emission-tested Printing Press” quality seal awarded by the German Institution for Statutory Insurance and Prevention in the Printing and Paper Industry to confirm that the press complies with the strict limit values. This applies to all conventional and UV presses.

A measuring device can be used to measure and display the machine's energy efficiency per 1,000 sheets during production. This allows the operator to run the machine with exceptional energy efficiency. Another way of reducing energy requirements is to employ a heat recovery system to reuse heat from the exhaust air of the DryStar® Combination dryer for the drying process. The Star System peripherals are perfectly coordinated with the press. They are highly efficient and designed to conserve energy and resources. Reducing or completely eliminating the use of alcohol makes another important contribution to ensuring environmentally friendly print production. This results in a print process that delivers eco-friendly operation at lower costs.

New features of the Speedmaster XL 106 at a glance:

- Sheet format of 75 × 106 cm (29.53 × 41.73 in) for greater sheet utilization in packaging and commercial printing
- Control panels with glass touchscreen at the feeder, printing unit, and coating unit for intuitive, ergonomic, and standardized operation of the entire machine
- New gallery and printing unit guard design that meets the highest ergonomic standards
- Automatic non-stop device at the feeder and delivery for uninterrupted pallet changes during full production
- Innovative system for perfecting printing at 18,000 sheets per hour with exceptionally stable sheet travel
- Color Package for shorter makeready times, less paper waste, and enhanced productivity, comprising:
 - Prinect® Inpress Control
 - Color Assistant Pro
 - Program-controlled pre-inking and ink vibrator throw-off
 - Digitally controlled ink zone motors
- PowderStar® AP 500 with an innovative powdering system that cuts powder consumption by 50 percent

This information and all subsequent details are dependent on press configurations, job structures, and in-house processes. Some of the components mentioned are not included in the standard scope of delivery.

The First Step to Successful Production. The Preset Plus Feeder Creates the Best Possible Conditions from the Outset.



The perfect start for top productivity – the Preset Plus Feeder of the Speedmaster XL 106.

The perfect start. The Preset Plus Feeder of the Speedmaster XL 106 sets the course for successful production in every respect. Its exceptionally reliable sheet separation, smooth and precise transport of the sheet into the feeder of the first printing unit, and excellent feed registration lay the foundation for optimum results at top print speeds of up to 18,000 sheets per hour.

The extremely high level of automation reduces makeready times and maximizes productivity. A multi-stage sheet monitoring system ensures stable production conditions across the board. During transfer to the first printing unit, the Preset Plus Feeder ensures excellent print quality right from the start.

Preset Plus Feeder technology at a glance:

- Feeder control panel and control panel at the first printing unit with glass touchscreen for intuitive and ergonomic operation of feeder and press functions
- Preset function for fully automated feeder adjustment based on the job data
- Automatic air presettings controlled by characteristic curves based on format and substrate thickness
- Speed-compensated blast air for reliable sheet separation at any speed
- Automatic sheet arrival control for uninterrupted production
- Venturi technology at the front lays for optimum sheet positioning
- Pneumatic pull lay for precise, mark-free sheet alignment and excellent feed registration
- Multi-stage sheet monitoring system consisting of a multiple sheet detector and ultrasonic and pull lay double-sheet detectors
- Shingle stream control for the detection of foreign particles, particularly when processing cardboard
- Autopile and Autopile Plus roller conveyor system for automatic material flow
- Fully automatic non-stop device for uninterrupted pallet changes
- Suction brush for removing dust from the sheet cuts paper waste and extends washup intervals



Control panels at the Preset Plus Feeder and at the first printing unit – intuitive and ergonomic.

Suitable Star System peripherals:

- CutStar®: Sheeter for processing more cost-effective reel stock
- StaticStar®: Anti-static system minimizes static charges and optimizes sheet travel when processing substrates such as plastic foils

The advantages for your printing process:

Makeready times: Fully automated setting of the Preset Plus Feeder wins you up to five minutes additional production time, often far longer with difficult substrates. • **Productivity:** The entire Preset Plus Feeder is designed for a stable production speed of up to 18,000 sheets per hour – across a wide range of substrates. • **Quality:** Precise feed registration and the ability to process scratch-sensitive materials deliver a high level of quality. • **Ergonomics:** In addition to centralized control at the Prinect Press Center, you can also change the machine settings using the touchscreen at the feeder and the control panel at the first printing unit. This cuts down the operator's legwork and makes operation even more ergonomic and time-saving. • **Environment:** The precision of the CutStar sheeter reduces paper waste. This in turn helps conserve valuable resources and cut CO₂ emissions.

Precision at its Best. Maximum Automation of Printing and Coating Units Minimizes Makeready Times.



The printing units and coating units are equipped throughout with intuitive touch operation.

The printing unit – quality and minimal makeready times. The printing unit design enables extremely smooth running at production speeds of up to 18,000 sheets per hour with optimum print results from the first sheet to the last. However, quality is just one factor in ensuring business success. Makeready times also play an important role in enhancing press efficiency. Fully automatic, simultaneous plate changes, impressively short washup times, and ergonomic and straightforward machine operation cut makeready times to an absolute minimum.

The coating unit – dazzling diversity. Equipped with a chambered blade system, the coating unit makes it possible to use a wide range of different coatings. Reproducible high-precision application delivers outstanding coating results, even at top speeds. It is extremely easy to operate the unit and clamp in coating plates and coating blankets, which saves valuable time during setup. If the coating unit is not required, it can be easily disconnected to achieve optimum sheet travel.

Printing unit technology at a glance:

- High-strength cylinder bearings maximize smooth running
- Combined printing-nip blowing unit for paper and cardboard can be preset and speed-compensated
- AutoPlate XL for fully automated, simultaneous plate changes
- Circumferential, lateral, and diagonal registers can be adjusted remotely via the Prinect Press Center®
- Automated, simultaneous washup devices for blanket and impression cylinders with optimized and customized washup programs
- Control panels with glass touchscreen for maximum ease of use and ergonomics thanks to optimum display and local operation

Coating unit technology at a glance:

- Chambered blade system for accurately metered coating application and straightforward operation
- Circumferential, lateral, and diagonal registers can be adjusted remotely via the Prinect Press Center
- Single-side and parallel pressure adjustment from coating form cylinder to impression cylinder and from screen roller to coating form cylinder via the Prinect Press Center
- Disconnection of the coating form cylinder enables optimum sheet travel when not using the coating unit

- Combination clamping system with central clamping mechanism enables rapid changing of coating blanket or coating plate
- The Multi Loader System – the motorized screen roller storage system with four rollers – is perfect for automated screen roller changeovers
- Control panel with glass touchscreen for maximum ease of use and ergonomics thanks to optimum display and local operation
- Inkjet modul for marking individual multiple-ups as waste in combination with Prinect Inspection Control or for imprinting individual information via alpha-numeric codes

Suitable Star System peripheral:

- CoatingStar®: Coating supply unit with wear-free annular piston pump for pulse-free coating feed and an integrated coating conditioning system

The advantages for your printing process:

Makeready times: Fully automated process steps save time. Optimized washup programs reduce your makeready times by up to a minute. A complete plate change on a Speedmaster XL 106 eight-color press, for example, takes up to four minutes less with AutoPlate XL than on a press equipped with AutoPlate Advanced. Depending on the job structure, the makeready time in the coating unit can be reduced by up to ten minutes per job thanks to rapid screen roller changing with the Multi Loader System, the combination clamping system for plates and blankets, and the fact that all relevant settings can be controlled remotely. • **Productivity:** The more job changes you perform, the more time you save with AutoPlate XL. Over 1,500 jobs, you can generate up to 100 hours of additional production capacity. • **Quality:** Whatever the speed and job sequence, you benefit from optimum, stable print quality – even with complex full-area, spot, metallic, and UV coatings. • **Integration:** You control the printing and coating units via the Prinect Press Center. Specific functions such as washup programs can also be started from the feeder control panel with glass touchscreen. • **Ergonomics:** Controlling the production process using the control panels with glass touchscreen at the printing and coating units is extremely ergonomic and saves valuable time thanks to local operation. • **Environment:** Optimized washup programs reduce the amount of washup solution and the number of washup cloths used to an absolute minimum. CoatingStar minimizes coating consumption by ensuring residual amounts are as small as possible.

Top Quality – For Every Single Dot.
The Fast-Response Inking and Dampening
System Delivers Consistent Color Stability.

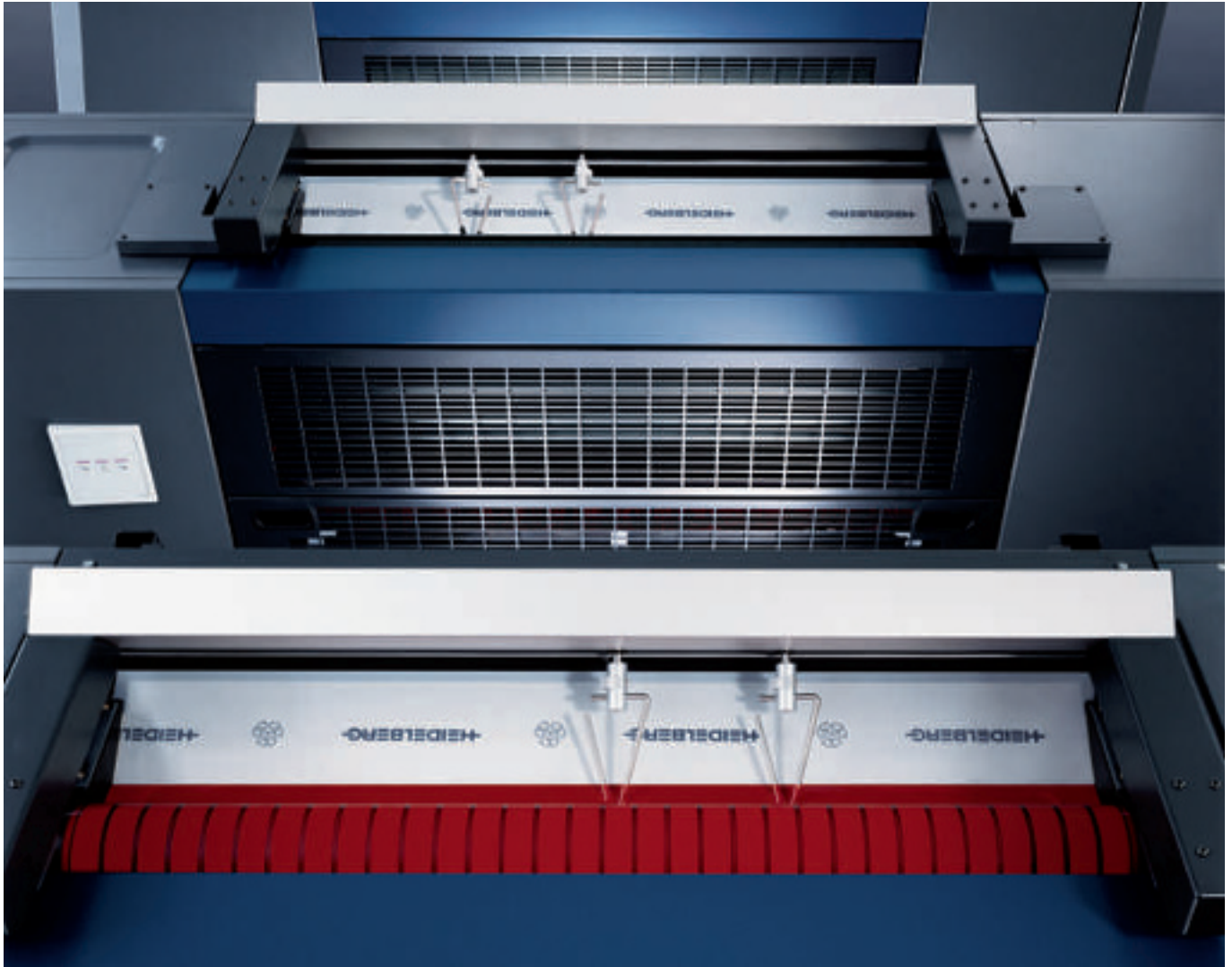

Stable inking with Hycolor and fast ink changes with the ink fountain liner.

Innovations in color. The Hycolor inking and dampening system sets new standards. The special geometry of the inking units makes it possible to achieve high contrast and absolute dot definition, not to mention smooth solids – and all at speeds of up to 18,000 sheets per hour. Hycolor delivers a stable ink/water balance fast.

Setup times are minimized and the OK sheet is produced very quickly. All inking and dampening system settings can be input and stored via the Prinect Press Center while the previous job is still in production.

Inking and dampening system technology

at a glance:

- Speed compensation controlled by characteristic curves determining the amounts of ink and dampening solution applied
- Ink fountain roller and inking unit temperature control for improved ink metering and a higher maximum ink film thickness
- Customized phase setting of the distributors for even ink density from the start of the sheet to its end
- Short-path inking mode for fast, stable inking with low ink consumption
- Ink flow with direct dampening solution addition for a rapid ink/water balance reduces makeready times and paper waste
- High inking unit stability with the shortest possible response time
- The distributor is switched off and the inking unit disconnected when printing is interrupted, thus retaining the color profile
- Optimized washup programs and ink fountain liner for fast and effective cleaning during ink changes
- Fully automated deep cleaning function with additional washup solution circuit for faster washing with special washup solutions
- The cleaning sheet function cleans the blankets, thereby removing the residual ink and cutting wash-up times
- Prinect Inpress Control measures and controls color and register inline during production

- Color Assistant Pro:
 - Fully automated monitoring of the ink fountain liner, self-calibration of ink zones, and automatic adjustment of characteristic curves for high-precision ink metering
 - Customized optimization of ink presets for different papers, inks, and printing conditions
- Color Fast Solution for a faster inking unit reaction during job or color changes and therefore less paper waste
- Color Package for shorter makeready times, less paper waste, and enhanced productivity, comprising:
 - Prinect Inpress Control
 - Color Assistant Pro
 - Program-controlled pre-inking and ink vibrator throw-off for extremely fast job changes, especially with varying ink coverage
 - Digitally controlled ink zone motors for high-precision ink feed and a very quick response during color control

Suitable Star System peripherals:

- CombiStar®: Combination unit with dampening solution supply and inking unit temperature control for stable printing conditions
- FilterStar®: Dampening solution filtration system for use with CombiStar
- InkStar®: Fully automatic ink supply from cartridges or drums to minimize the amounts of residual ink

The advantages for your printing process:

Makeready times: Color Assistant Pro calibrates the ink zones based on the condition of the ink fountain liner to ensure even faster inking-up for each job change. Prinect Inpress Control speeds up the setup process and saves you additional valuable time. • **Productivity:** Precise ink presets with Color Assistant Pro cut waste and save you time. • **Quality:** A stable ink/water balance delivers consistently high color stability and thus top-quality results. **Integration:** You control the inking and dampening system centrally from the Prinect Press Center. • **Environment:** Thanks to the pre-heating function, the inking unit temperature control cuts paper waste and reduces energy consumption. Color Assistant Pro and Prinect Inpress Control save waste sheets and thus conserve valuable resources. Using FilterStar extends the service life of the dampening solution and thus minimizes fresh water consumption.

On a Cushion of Air. Sheet Travel and the Perfecting Device Ensure Uncompromising Quality at Top Speeds.



Outstanding print quality in perfecting mode with the perfecting device of the Speedmaster XL 106.

Smooth running. The side frame, which is manufactured in a single casting, and a specially developed cylinder bearing system form the basis for extremely smooth running. The air-supported sheet transfer system smoothly guides each sheet contact-free from the printing unit right through to the delivery on a cushion of air.

Perfect sheet reversal. Register-accurate sheet transfer during the perfecting process and contact-free sheet travel are essential qualities in perfecting printing. To enable excellent print quality at production speeds of 18,000 sheets per hour even in perfecting mode,

the Speedmaster XL 106 has been equipped with a new perfecting concept, an adapted sheet guidance system, and a new delivery concept.

Increasing the speed of the perfecting press to 18,000 sheets per hour boosts the average production speed and cuts throughput times. Depending on the job spectrum, this can lead to a 20 percent rise in productivity.

Perfecting device technology at a glance:

- Fully automatic changeover
- Excellent register accuracy and smooth sheet travel with both thin paper and substrate thicknesses of up to 0.80 mm (0.0315 in)
- Central control via the Prinect Press Center
- Variable AirTransfer System for perfect sheet travel, even in perfecting mode
- Innovative system for perfecting printing at 18,000 sheets per hour:
 - Separate air characteristic curves for short grain and long grain paper
 - Dynamic sheet distance control in the perfecting device
 - Sheet guide plates with innovative Air Jet technology for contact-free sheet travel
 - Modified storage drum
 - Improved reversing drum with innovative pincer gripper system for a higher retaining force and improved dynamic gripper opening and closing
 - Adapted storage and sheet travel
 - Innovative sheet travel concept with adapted preset values, profiles, printing-nip blowing unit, and optimized collapsible cylinder shells

Sheet travel technology at a glance:

- AirTransfer System with automatic air settings – controlled by characteristic curves and speed-compensated
- TransferJacket Blue, the jacket for transfer cylinders, and the PerfectJacket impression cylinder jacket for optimum print quality and minimal cleaning
- Quick-action clamping device for the PerfectJacket impression cylinder jacket for short downtimes during changeovers
- Sheet travel monitoring in the printing unit
- Wing grippers support the edges of thin sheets
- Cardboard kit with additional components for ideal sheet travel when using stiff materials

Suitable Star System peripherals:

- ScrollStar®: Compressed air supply system for air that is free of oil and condensation
- AirStar®: Central air supply system that combines almost all individual blowers for suction and blast air in a central air supply cabinet

The advantages for your printing process:

Makeready times: You can save up to five minutes thanks to the fully automatic changeover procedure, especially when changing from thin to very thick substrates. • **Productivity:** You achieve the ultimate in productivity through consistently high production speeds of up to 18,000 sheets per hour – even in perfecting mode. • **Integration:** All key format and air settings can be preset based on the length, width, and thickness of the printing stock. All key functions of the perfecting device can be managed quickly, easily, and centrally via the Prinect Press Center. • **Quality:** You achieve exceptional printing quality thanks to scratch- and mark-free sheet travel. • **Environment:** AirStar and ScrollStar make an important contribution to protecting the environment with energy savings of up to 50 percent.

Perfection All the Way to the Pile. The Preset Plus Delivery Creates Ideal Conditions for Finishing.



18,000 sheets per hour in perfecting mode – no problem for the Preset Plus Delivery.

Gentle, tidy, and neatly aligned. The Preset Plus Delivery rounds off the printing process and creates the ideal conditions for fast and smooth finishing. It impresses with optimum sheet travel and precisely aligned piles. The delivery's high degree of automation cuts makeready times and boosts productivity significantly.

Fast results. Increasing the production speed to 18,000 sheets per hour in perfecting mode improves productivity considerably. To ensure the outstanding printing quality continues through to the delivery pile, the Preset Plus Delivery has been adapted as part of the innovative system for perfecting printing at 18,000 sheets per hour. From the transfer of each sheet to the delivery all the way through to pile formation, all the key components have been adapted to meet the high requirements for double-sided printing in a single pass – the ideal delivery for maximum quality in perfecting mode.

Preset Plus Delivery technology at a glance:

- Automatic positioning of all sheet guidance elements
- Straightforward operation with glass touchscreen and jogwheel
- Suction segment disks on the sprocket wheel shaft ensure reliable sheet travel in perfecting printing
- Dynamic sheet brakes for higher print speeds and smooth deceleration
- Individually adjustable delivery air system and rear-edge suction device for precise stacking, even with low grammages
- Variable gripper opening for perfect stacking in line with the substrate thickness
- Three different non-stop systems, tailored to a wide range of requirements:
 - Automatic non-stop device with rake (for packaging printers who use Logistics from Heidelberg or system pallets)
 - Automatic non-stop device with conveyor table (for packaging printers who use wooden or disposable pallets)
 - Automatic non-stop device with conveyor table and rake (for label and commercial printers)
- New innovative delivery concept for perfecting printing at 18,000 sheets per hour:
 - Delivery with an extension module
 - Optimized position for powder application
 - CleanStar® for efficient powder extraction
 - Improved sheet guide plates and sheet guidance
 - Adapted preset values and characteristic curves
 - Optimized delivery air system

Suitable Star System peripherals:

Delivery

- PowderStar AP 500: Innovative powdering system that cuts powder consumption by 50 percent
- PowderStar AP 500 Duo: Powder spray device for even, double-sided, and turbulence-free powder application
- CleanStar: Process air extraction system for odors, powder particles, and paper dust

Drying

- DryStar Ink: Ink dryer with infrared module
- DryStar Combination: Infrared/hot-air dryer and circulating-air dryer, with additional hot-air dryers in the extended delivery for excellent drying results with demanding, conventional coating applications
- Heat recovery: From the exhaust air of the DryStar Combination dryer – for reuse during the drying process
- DryStar LE (Low Energy) UV: Cost-efficient solution for standard applications, for curing all UV inks and coatings
- DryStar UV: Specialist solution for demanding applications, such as metallic effects or Iriodin, for curing all UV inks and coatings and spot color inks
- DryStar Combination UV: Solution for drying and curing applications in both conventional and UV operation
- DryStar Advanced: Software option for automatic dryer settings

The advantages for your printing process:

Makeready times: You benefit from exceptionally short makeready times thanks to automatic delivery setting using preset functions. The dynamic sheet brake, suction segment disks, and delivery air system in particular deliver an extra three to five minutes of production time. • **Productivity:** All components are designed for stable production at maximum speed. The dynamic sheet brake enables production speeds that are up to 20 percent faster, particularly for thin substrates. • **Quality:** Scratch-free and smudge-free sheet travel all the way to the pile delivers optimum print results. The pile has neatly aligned edges for optimum finishing. • **Integration:** You control all the functions of the delivery's DryStar dryers centrally via the Prinect Press Center or at the feeder control panel with glass touchscreen. • **Environment:** Efficient powder application via PowderStar and the CleanStar process air extraction system cut the number of cleaning procedures and provide a better pressroom environment.

Prinect Press Center. The High-Performance Control Station.

Straightforward operation combined with precision control. In addition to serving as an intelligent control station for your Speedmaster press, the Prinect Press Center also integrates the machine into the comprehensive Prinect workflow from Heidelberg. The standardized operating concept paves the way for fast and reliable processes. All settings can be stored for repeat jobs, which maximizes performance and productivity – even with frequent job changes. Cutting-edge technology, time-saving automation, and perfect data management ensure the ideal conditions for efficient production on a lasting basis.

Data is entered and settings are made via a convenient touchscreen interface. During job changes, the innovative, process-oriented Intellistart® operator guidance system uses all the relevant information on both the current and the next job for optimum makeready processes planned down to the last detail.

Integration with Prinect. The high-performance Prinect Press Center control station, and the Prinect Axis Control®, Prinect Image Control, and Prinect Inpress Control color measurement systems form a perfectly coordinated unit.

Overview of all press operations. The Prinect Press Center gives you the perfect overview. Its wallscreen – a large monitor integrated into the extraneous light

shield – ensures ideal interaction between the operator and press and provides a comprehensive overview of all press operations.

Innovative technology. The innovative, web-based Prinect Performance Benchmarking tool tells you exactly how productively you are working and how your print shop compares with the competition.

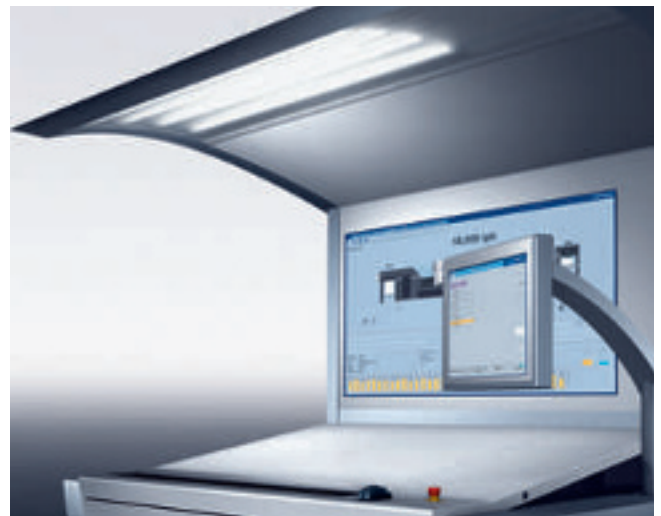

Prinect Press Center – the high-performance control station of the Speedmaster XL 106.

The advantages for your printing process:

Makeready times: The Prinect Press Center cuts the number of operations per job change by up to 70 percent.

Productivity: The Prinect Press Center raises annual production capacities by up to 8 percent. • **Quality:** The optimally integrated unit comprising control station and color measuring/image inspection system provides a unique quality assurance system. • **Integration:** Full integration into the Prinect workflow delivers the ultimate in data management at the control station. • **Ergonomics:** The ergonomic Prinect Press Center ensures extremely user-friendly operation and a more pleasant and efficient working environment. • **Environment:** Substantial paper savings thanks to controlled processes.

Working in Perfect Harmony. Star System Peripherals and the Speedmaster XL 106 – A Strong Team.

Everything from a single source. The Star System from Heidelberg features peripherals tailor-made for the press. Perfectly coordinated and integrated components pave the way for short makeready times, maximum productivity, high print quality, and optimum energy efficiency. Star products are also easy to operate, because all components are controlled via the Prinect Press Center. Installation and servicing are carried out by experts from Heidelberg. This creates an integrated solution consisting of the press itself and individually coordinated high-performance peripherals.

The Star System also makes an important contribution to environmentally friendly print production with the Speedmaster XL 106. Less dampening solution, washup solution, powder, and paper waste make the system more ecological and economical.

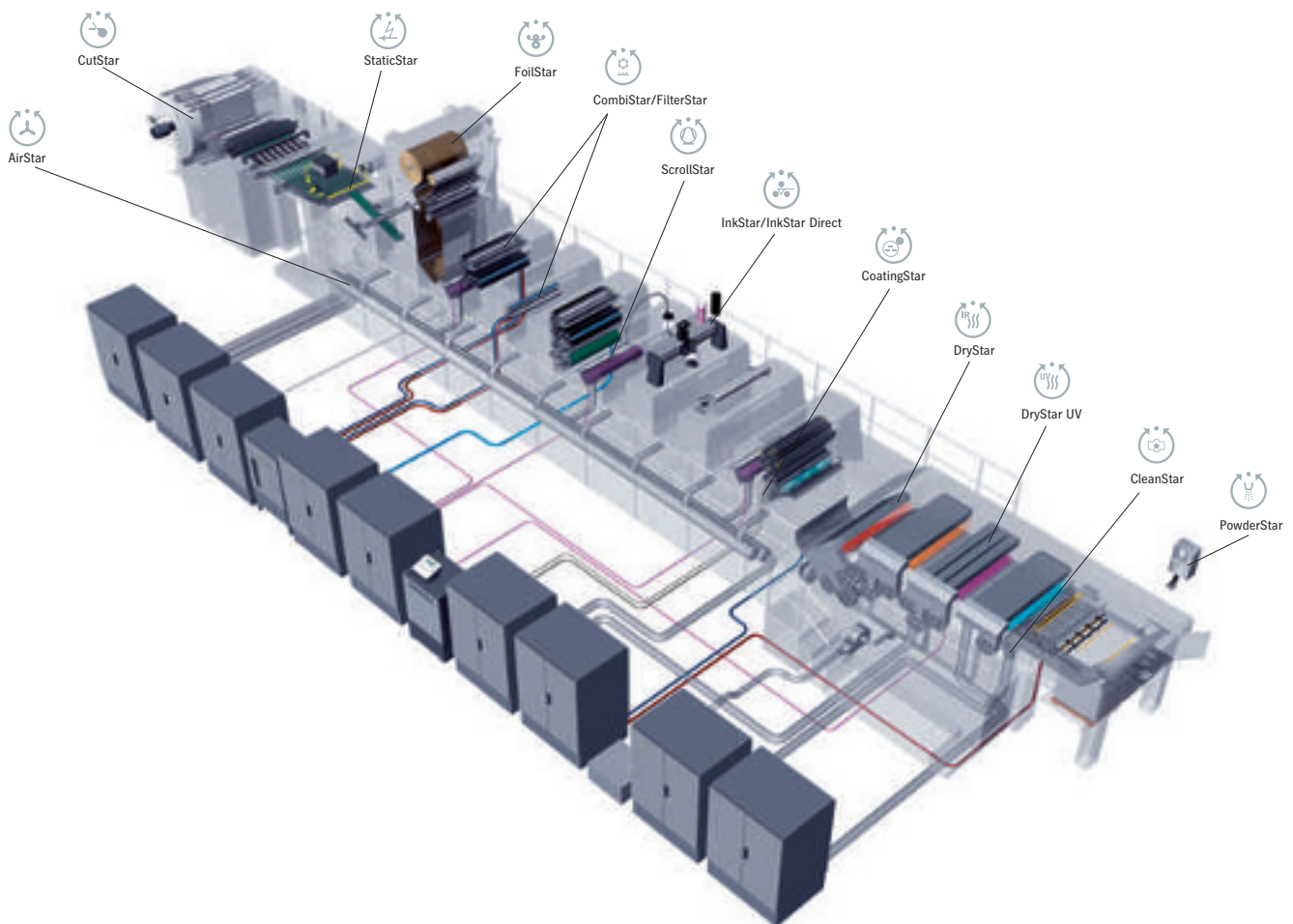

The perfect combination – Speedmaster XL 106 and the Star System.

Boosting your performance.

Heidelberg Services offers a comprehensive portfolio extending from technical and machine-based services to coordinated consumables and a wide range of training and consulting services. All the services are designed to help print media companies strengthen and expand their performance and competitiveness in the long term.

Technical services and consumables. Stable production and maximum machine availability lay the foundation for efficiency and top performance. This is why Heidelberg Systemservice® offers service packages for all aspects of the press, service parts service, and technical support. With Saphira® consumables, you benefit from perfectly coordinated products from Heidelberg.

Productivity optimization. To ensure maximum productivity coupled with top quality, Heidelberg experts identify potential for improvement in your print shop. Print Color Management helps you shorten make-ready times and cut waste while maintaining the same high print quality.

Process optimization. This service is used to analyze your processes, develop measures for improvement, and train your staff. Prinect®, the print shop workflow from Heidelberg, helps cut your workload and boost your profit.

People development. The training and advisory services of the Print Media Academy (PMA) ensure your specialists and managers acquire comprehensive expertise and strategic know-how.

Business development. Heidelberg consultants work with you to analyze the strengths and weaknesses of your company, identify potential for improvement, and then derive the optimum market positioning strategy.

Equipped for the future with Heidelberg. The portfolio of Heidelberg Services provides print shops with far-reaching support to set the course for future success. The experts of Heidelberg Services offer a broad range of specialist know-how in the search for solutions.

Heidelberg Services

Technical services and consumables: For stable production and maximum availability. • **Productivity optimization:** For maximum productivity and top quality. • **Process optimization:** For efficient production processes from a single source. • **People development:** For comprehensive expertise throughout the company. • **Business development:** For successful business and higher profit.



Inside View of the Speedmaster XL 106

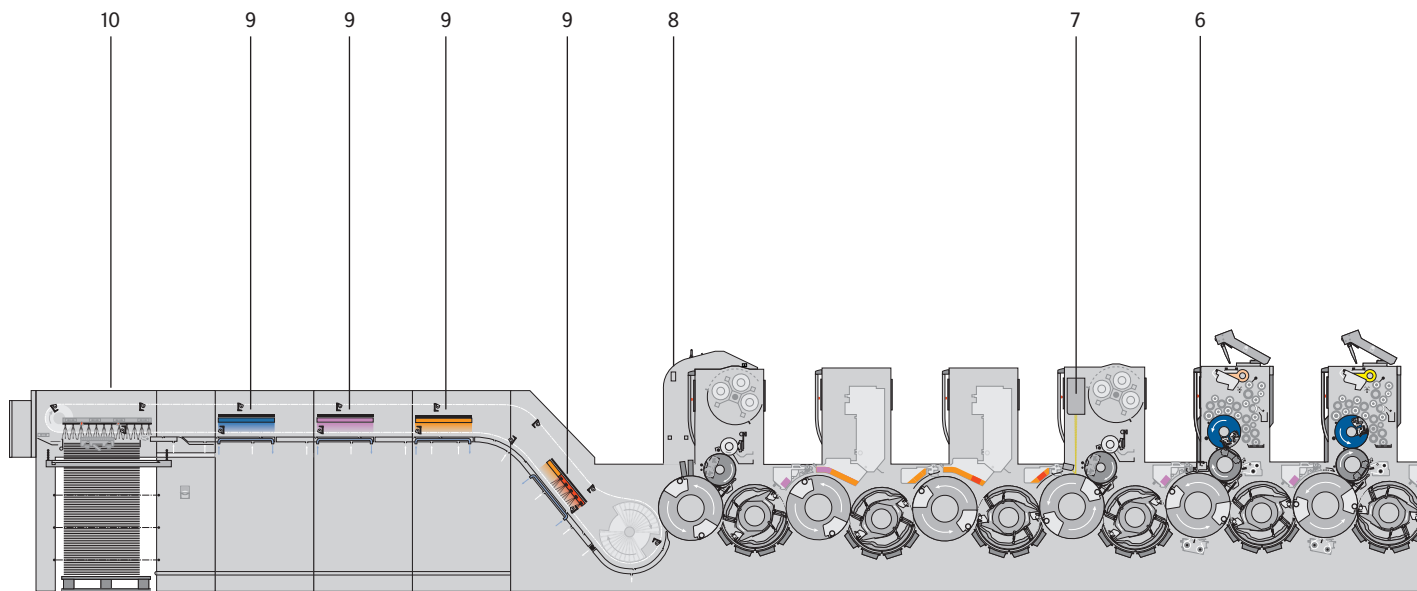

The press shown here is a sample configuration. Some of the features shown are optional.

LPL – coating, reversal, coating

Greater flexibility, faster throughput times, and thus shorter makeready times – the Speedmaster XL 106 LPL prints and coats both sides in a single pass, which cuts the waiting and drying times prior to postpress operations. The option of applying functional coatings (e.g. barrier coating) to the inside of packaging and a gloss coating to the outside means that the LPL press appeals to packaging print shops, too.

Inkjet modul – added value through process reliability and customization

In combination with Prinect Inspection Control, individual multiple-ups can be marked as waste, e.g. through the destruction of the adhesive flap code, and subsequently ejected in an inline process in the folding carton gluing machine. It is also possible to imprint alphanumeric codes (e.g. batch numbers, date).

UV – the integrated solution ex works

Perfect coordination of all the components ensures that the Speedmaster XL 106 delivers maximum performance in UV operation, too. The UV dryers have been awarded the “Energy-minimized UV Printing” test certificate from the German Institution for Statutory Insurance and Prevention in the Printing and Paper Industry.

LYYL – pioneering overall concept for double-coating applications

The Speedmaster XL 106 LYYL not only allows you to combine conventional inks and a UV coating – it also offers a broad range of finishing options, such as matt/gloss effects and full-area and spot coatings with dispersion coating and/or UV coating. The option of storing all dryer settings enables accurate reproduction of repeat jobs in no time at all.

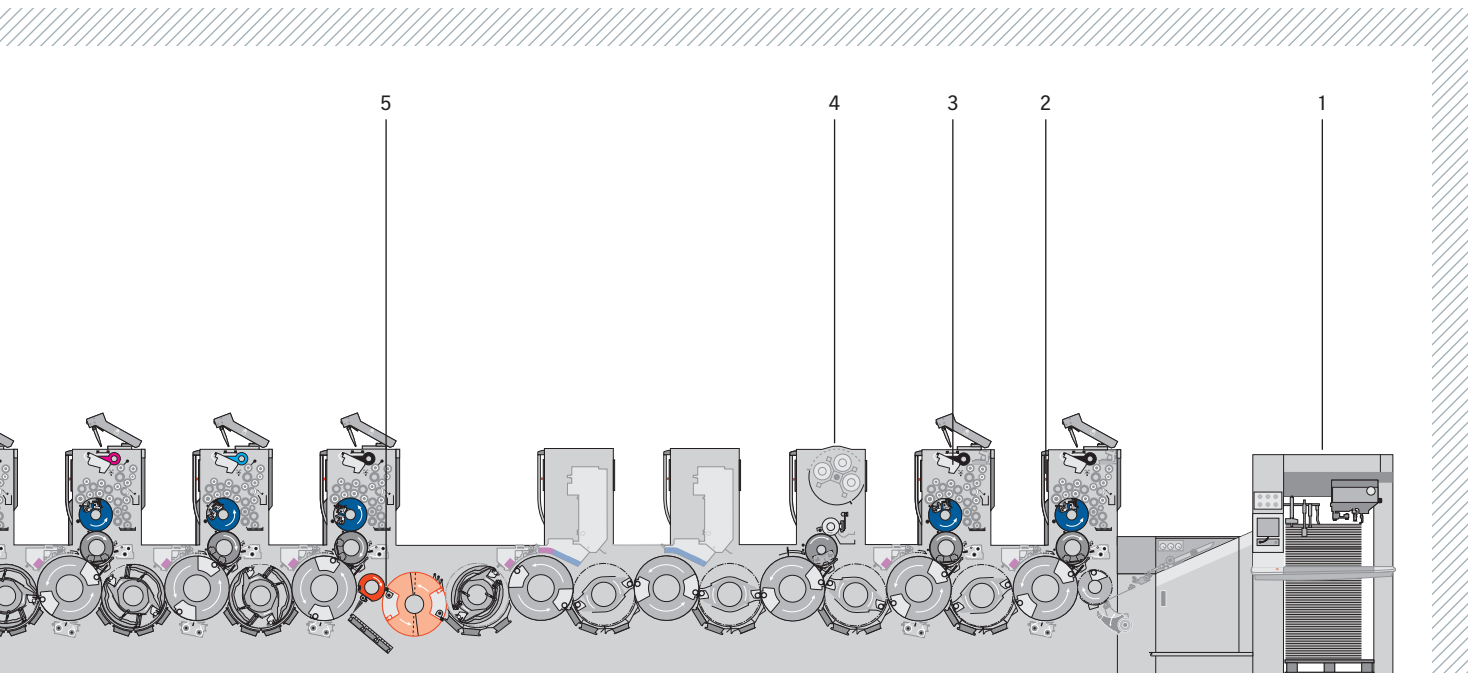

- 1 The Preset Plus Feeder adopts all relevant format and air settings for extremely short makeready times and stable sheet travel.
- 2 The fully automatic simultaneous plate changer AutoPlate XL works in conjunction with Intellistart for automated job changes to reduce makeready times considerably.
- 3 The Hycolor inking and dampening system offers fast response times and color stability. All functions can be controlled remotely, including the short-path inking mode for low ink consumption.
- 4 The coating unit with chambered blade system, the Multi Loader System for automated screen roller changeover, and CoatingStar with its pulse-free coating feed and integrated coating conditioning system match state-of-the-art flexographic units in every respect.
- 5 The perfecting device with fully automated changeover combines with the PerfectJacket impression cylinder jacket and the variable AirTransfer System to deliver outstanding print quality in perfecting mode.
- 6 Prinect Inpress Control measures and controls color and register inline during production.
- 7 Prinect Inspection Control supports inline sheet inspection for maximum process reliability. Each sheet is checked inline using two high-resolution cameras. Prinect Inspection Control is available as a color inspection system (RGB) or a gray scale inspection system with additional PDF comparison.
- 8 Inkjet modul in combination with Prinect Inspection Control, for marking individual multiple-ups as waste and for imprinting individual information about alphanumeric codes.
- 9 The DryStar Combination dryer system from Heidelberg has been specifically coordinated with sheet travel to ensure perfect drying results.
- 10 The Preset Plus Delivery enables high-precision pile formation, while the presettable dynamic sheet brake decelerates sheets in a controlled manner. Settings are made automatically using presetting data.

Heidelberger Druckmaschinen AG

As a technology pioneer in our industry, we're constantly pushing boundaries. We have become a leading international solution and service provider to the print media industry thanks to our innovative strength, cutting-edge technology, and closeness to customers. We supply not only extremely high-performance equipment covering the entire value-added chain in sheetfed offset printing but also digital printing systems for hybrid applications or extremely short runs. Our complementary services and training and advisory portfolios significantly enhance print shops' economic performance and green credentials.

We give you the solutions that meet your customers' needs. Find out about the customized products and services from Heidelberg that will strengthen your company in the long term on every market.

Discover HEI – for print media business with a future.

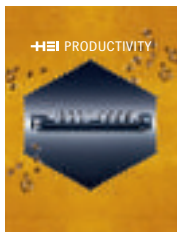

HEI Productivity: Boost your productivity with seamless processes and efficient and reliable production equipment from Heidelberg.

HEI Eco: Production equipment from Heidelberg ensures that eco-friendly printing also makes economic sense – true to our motto “Think economically, print ecologically”.

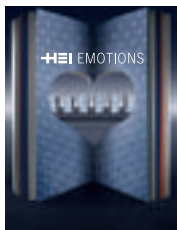
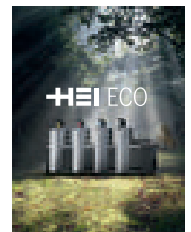

HEI Emotions: Use our surface finishing techniques to transform feelings and original ideas into visual and haptic experiences.

HEI Integration: We can provide you with the software you need for your online operations with our Prinect print shop workflow.



HEI Flexibility: Our digital and offset printing range gives you the flexibility you need to handle any kind of job.

HEI End: Our postpress technologies transform your print products into bestsellers that fly off the shelves.

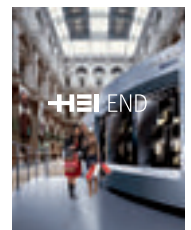

HEI School: Hone your skills and expertise with training courses, seminars, and know-how from our Print Media Academy.

HEI Quality: Ensuring top quality is your aim – and ours, too.



Heidelberger Druckmaschinen AG

Kurfuersten-Anlage 52-60

69115 Heidelberg

Germany

Phone +49 6221 92-00

Fax +49 6221 92-6999

www.heidelberg.com



FSC® C008807

The mark of
responsible
forestry



Id-Nr. 1115046

www.bvdm-online.de

Publishing Information

Printed in: 04/12

Photographs: Heidelberger Druckmaschinen AG

Platemaking: Suprasetter

Printing: Speedmaster

Finishing: Stahlfolder, Stitchmaster

Consumables: Saphira

Fonts: HeidelbergGothicML

Printed in Germany

Trademarks

Heidelberg, the Heidelberg logotype, AirStar, CleanStar, CoatingStar, CombiStar, CutStar, DryStar, FilterStar, Hycolor, InkStar, Intellistart, PowderStar, Prinect, Prinect Axis Control, Prinect Press Center, Saphira, ScrollStar, Speedmaster, Stahlfolder, StaticStar, Stitchmaster and Suprasetter are registered trademarks of Heidelberger Druckmaschinen AG in the U.S. and other countries. All other trademarks are property of their respective owners.

For details on the emissions of the Speedmaster XL 106 please visit us at www.heidelberg.com/emissiondetails

Subject to technical modifications and other changes.